

On the Nonlinear Shaping Gain with Probabilistic Shaping and Carrier Phase Recovery

Stella Civelli, *Member, IEEE*, Emanuele Parente, Enrico Forestieri, *Senior Member, IEEE*, and Marco Secondini, *Senior Member, IEEE*

Abstract—The performance of different probabilistic amplitude shaping (PAS) techniques in the nonlinear regime is investigated, highlighting its dependence on the PAS block length and the interaction with carrier phase recovery (CPR). Different PAS implementations are considered, based on different distribution matching (DM) techniques—namely, sphere shaping, shell mapping with different number of shells, and constant composition DM—and amplitude-to-symbol maps. When CPR is not included, PAS with optimal block length provides a nonlinear shaping gain with respect to a linearly optimized PAS (with infinite block length); among the considered DM techniques, the largest gain is obtained with sphere shaping. On the other hand, the nonlinear shaping gain becomes smaller, or completely vanishes, when CPR is included, meaning that in this case all the considered implementations achieve a similar performance for a sufficiently long block length. Similar results are obtained in different link configurations (1×180 km, 15×80 km, and 27×80 km single-mode-fiber links), and also including laser phase noise, except when in-line dispersion compensation is used. Furthermore, we define a new metric, the nonlinear phase noise (NPN) metric, which is based on the frequency resolved logarithmic perturbation models and explains the interaction of CPR and PAS. We show that the NPN metric is highly correlated with the performance of the system. Our results suggest that, in general, the optimization of PAS in the nonlinear regime should always account for the presence of a CPR algorithm. In this case, the reduction of the rate loss (obtained by using sphere shaping and increasing the DM block length) turns out to be more important than the mitigation of the nonlinear phase noise (obtained by using constant-energy DMs and reducing the block length), the latter being already granted by the CPR algorithm.

Index Terms—Optical fiber communication, nonlinear fiber channel, probabilistic shaping, phase noise.

I. INTRODUCTION

PROBABILISTIC amplitude shaping (PAS) has been recently widely investigated as a way to improve the performance of an optical fiber network. PAS allows to finely adapt the information rate to the system requirements (channel signal-to-noise ratio (SNR) and forward error correction (FEC) code) and to reduce the gap to the Shannon limit

in the linear regime [2]–[4]. The SNR gain—up to 1.53 dB for large constellation size [5]—depends on the particular implementation of PAS, handled by the distribution matcher (DM). The DM maps k independent input bits with uniform distribution to N output amplitudes with the desired Maxwell–Boltzmann (MB) distribution—the optimal one in the linear regime. To do so, the DM imposes some specific constraints (e.g., a constant composition or a maximum energy) on the N symbols of each block, which are therefore *correlated*. While a DM can be implemented in different ways, its performance generally improves with the block length N . In fact, the correlation between the symbols of each block decreases when N increases, allowing to encode more information per transmitted symbol. For $N \rightarrow \infty$, the correlation vanishes and the DM output looks like an i.i.d. source with MB distribution, yielding the optimal PAS gain in the linear regime for a given rate and constellation size [5].

Previous studies on PAS concerned the DM implementation and PAS performance in the linear regime, aiming at reducing the rate loss—a useful performance metric defined as the difference between the entropy of the target MB distribution and the actual DM rate k/N —with reasonable computational complexity, hardware requirements, and flexibility [3]. For instance, sphere shaping (SS), implemented through the enumerative sphere shaping (ESS) algorithm, provides the best performance for a given block length [6]–[8]; constant composition DM (CCDM), implemented by arithmetic coding, is a simple and flexible technique to obtain the desired target distribution [9], [10]; hierarchical DM (Hi-DM) is an effective approach to combine several short DMs (based, e.g., on simple look-up tables) to form a long DM with good performance and low complexity [11]–[14]. In general, it was shown that increasing the block length N of the DM reduces the rate loss and improves the performance in the linear regime, without any downside (but for the increased latency and difficulties in the DM implementation). The interaction of carrier phase recovery (CPR) algorithms and PAS was investigated in [15], considering the ideal MB distribution in the linear regime.

More recently, the performance of PAS in the nonlinear regime has been studied [4], and it was shown, firstly for SS [16] and later for CCDM [17], [18], that increasing the block length at will is not beneficial. Indeed, the constraints induced by the DM on the N symbols of each block, besides reducing the rate of the source causing a rate loss, usually reduce also the intensity fluctuations on the signal, hence reducing the amount of nonlinear interference generated by each channel and yielding an additional *nonlinear shaping gain*. In this

S. Civelli, formerly with the Institute of Telecommunications, Computer Engineering, and Photonics (TeCIP), Scuola Superiore Sant’Anna, Pisa, Italy, is now with the Cnr-Istituto di Elettronica e di Ingegneria dell’Informazione e delle Telecomunicazioni, Pisa, Italy, and with the National Laboratory of Photonic Networks, CNIT, Pisa, Italy. E. Forestieri and M. Secondini are with the Institute of Telecommunications, Computer Engineering, and Photonics (TeCIP), Scuola Superiore Sant’Anna, Pisa, Italy, and with the National Laboratory of Photonic Networks, CNIT, Pisa, Italy. E. Parente is with the Institute of Telecommunications, Computer Engineering, and Photonics (TeCIP), Scuola Superiore Sant’Anna, Pisa, Italy. Email: stella.civelli@cnr.it.

This paper was presented in part at the European Conference on Optical Communication (ECOC), Bruxelles, Belgium, December 6-10, 2020. [1]

case, the correlation induced by the DM is beneficial, so that the nonlinear shaping gain decreases as N increases, vanishing for $N \rightarrow \infty$. Therefore, there is an optimal block length that maximizes the shaping gain by providing the best trade-off between linear and nonlinear gain. The nonlinear interference due to DM was analyzed in [19] for the CCDM, while the kurtosis-limited sphere shaping, which selects the sequences with minimum energy and low kurtosis, showed superior performance in the nonlinear regime with respect to equivalent-length ESS in a single-span scenario but not for a multi-span link [20]. Furthermore, it was shown that the nonlinear shaping gain improves by properly packing shaped sequences in time and frequency [21].

However, it is also known that a good part of the inter-channel nonlinear interference generated by intensity fluctuations (which are reduced by a short-block-length DM, as explained above) manifests as correlated phase noise, which can be mitigated also by a properly optimized CPR algorithm [22]–[26]. Unfortunately, a preliminary study on the interaction between the nonlinear shaping gain and CPR algorithms showed that the gain provided by the two techniques is very similar and does not add up [1]. Similar conclusions were drawn by an analytical study about the interaction of CPR and CCDM for cross phase modulation [27]. This effect is particularly relevant from a system design perspective, since a carrier recovery algorithm is always included in practical systems, meaning that the nonlinear shaping gain observed in simulations in the absence of a carrier recovery algorithm, might in fact disappear (or be drastically reduced) in realistic systems. In this work, we extend the analysis in [1] to assess the interaction between CPR and PAS in terms of nonlinearity mitigation in a wavelength-division multiplexing (WDM) scenario. This is done by including the laser phase noise in the system, highlighting the performance of different PAS and DM implementations, considering different scenarios, and introducing a new performance metric to study and predict this interaction.

II. PROBABILISTIC AMPLITUDE SHAPING

PAS is implemented at the transmitter by using four identical DMs. Each DM maps k uniformly distributed bits to N shaped amplitudes, A_1, \dots, A_N . The $4N$ amplitudes are then combined with $4N$ signs (obtained from other $4N$ uniform bits) and mapped to the four components of N dual-polarization QAM symbols (i.e., $4D$ symbols).¹ The amplitude-to-symbol mapping can be done in different manners. Here, we consider the two maps sketched in Fig. 1, referred to as *serial map* and *parallel map*. On the one hand, the serial map maps the N amplitudes generated by the first DM to the four components of the first $N/4$ $4D$ symbols, the N amplitudes generated by the second DM to the four components of the next $N/4$ $4D$ symbols, and so on. On the other hand, the parallel map maps the N amplitudes of the first DM to the first component of the N $4D$ symbols, the N amplitudes of the second DM to the second component of

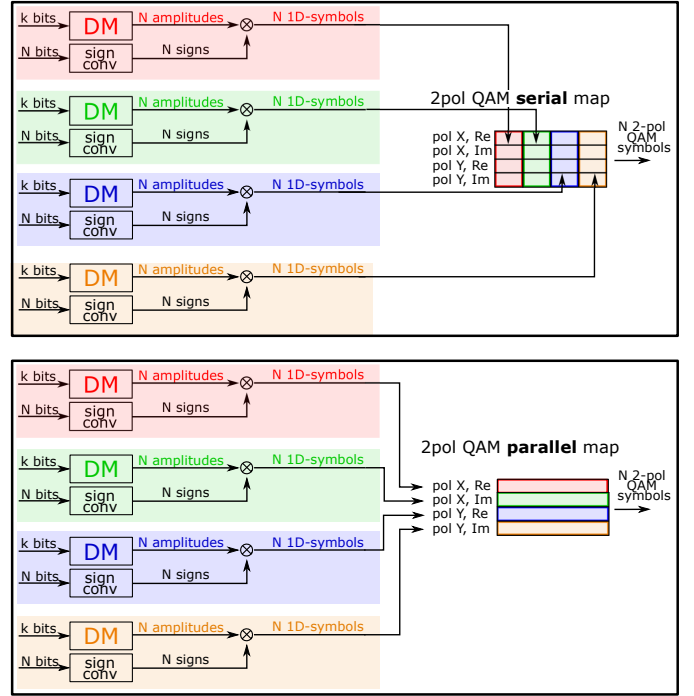

Figure 1. Different mappings to generate N 2-pol QAM symbols from $4N$ amplitudes generated by four instances of the same DM and $4N$ i.i.d. bits used for the signs.

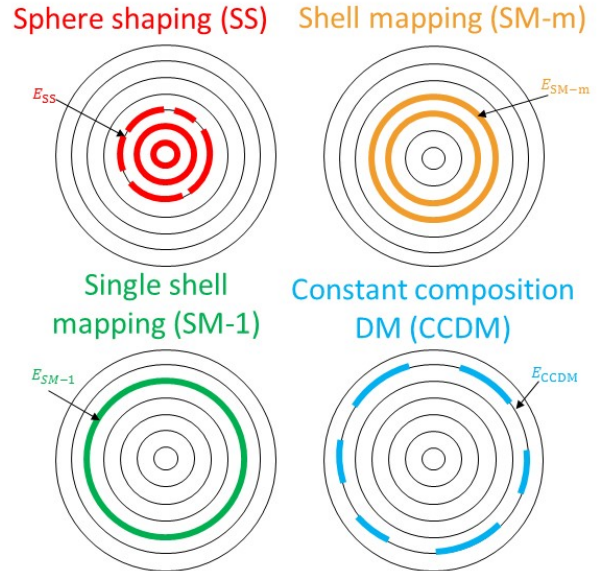

Figure 2. 2D energy description of different DM techniques. Black thin circles represent possible energy levels.

¹The reverse concatenation with the FEC is irrelevant to this description and is, therefore, omitted.

the N 4D symbols, and so on. While the serial map induces a stronger correlation (the four components are correlated) on a shorter block of $N/4$ adjacent symbols, the parallel map induces a weaker correlation (the four components are independent) on a longer block of N adjacent symbols. The two maps are equivalent in the linear regime but, as we will see in the following, they provide different performance in the nonlinear regime.

For the PAS implementation, we consider different DM techniques: SS, shell mapping (SM), and CCDDM, as described below. The energy distribution of the methods is qualitatively depicted in Fig. 2.²

SS maps k bits to the 2^k lowest-energy sequences of N amplitudes. Thus, by representing each sequence as a point in an N -dimensional space, all the sequences must lie within the smallest possible sphere that contains at least 2^k sequences. The map covers all the sequences *inside* the sphere and some of the sequences *on* the sphere, as shown qualitatively in Fig. 2. For a given block length N and constellation size, SS maximizes the source rate for a given average energy, yielding the best performance in the linear regime. The average energy of the sequences is E_{SS} . In this manuscript, SS is implemented using the ESS algorithm [6], [28], [29], resorting to the double-trellis trick proposed in [13] and studied in [30] to obtain optimal performance; however, this is not the only way to implement SS [8] and a simple look-up-table could be used for short-block-lengths.

SM maps k bits to the 2^k lowest-energy sequences, with the additional constraint that at most m energy levels (shells) can be occupied—indicated as SM- m . Thus, SM-1 uses only sequences that lie in a single shell and, therefore, have the same energy; SM-2 uses two adjacent shells; and so on. When the number of shells increases, SM- m tends to SS. The energy of the sequences covered by SM- m is limited by a maximum and a minimum value, with E_{SM-m} being the average energy. Also SM is implemented by using the ESS algorithm; the recently proposed band-ESS can also be used [31]. In the following, we consider only two extreme cases: the single-shell case, denoted as SM-1, and the case with the maximum number of shells (but lower than SS), denoted as SM-max. The latter is obtained by adding one higher-energy shell to those used by SS and removing all the innermost ones that are no longer needed (the number of shells m varies in this case).

CCDDM maps k bits on 2^k amplitude sequences with the same composition, i.e., permutations of the same sequence [9], [32]. The composition is determined by the desired target distribution. Since the sequences have the same composition, they also have the same energy E_{CCDDM} and lie in a single shell, as in the SM-1 case.

In the linear regime, for a given block length N and constellation size, the PAS performance depends on the average energy E_{DM} of the 2^k sequences used by the considered DM.

²While in our manuscript we think of SS as a type of DM, a different perspective is given in [8], where the SS is proposed as an *indirect* method to implement PAS, as opposed to the *direct* methods implemented by a DM. This difference is, however, only a matter of definition and does not affect the practical realization of PAS.

It is simple to verify that $E_{CCDDM} \geq E_{SM-1} \geq E_{SM-2} \geq \dots \geq E_{SM-max} \geq E_{SS}$. Thus, the best performance is obtained with SS, then with SM- m (the performance decreasing with decreasing m), and eventually with CCDDM. As the block length N increases, all the mentioned methods approach an i.i.d. source with MB distribution [5], which yields the ultimate linear shaping gain (and zero rate and energy losses). For a given block length and constellation size, the rate loss, which is a very common performance metric for DMs in the linear regime, follows the same ranking indicated by the average energy, as shown in several recent publications including [17], [29].

On the other hand, in the nonlinear regime, the capacity-achieving distribution and, consequently, the optimal DM are unknown. However, some useful design guidelines can be obtained from approximated models or observations. For instance, it has been shown that the amount of nonlinear interference generated by a propagating signal depends not only on its average power (second-order moment), but also on its fourth-order moment (when symbols are i.i.d.) [23], [33]–[35] or, more in general, on the variations of the instantaneous power over a finite temporal window [19], [21], [36]. In this case, the use of a shorter block length N is expected to be beneficial, as it introduces a constraint on the energy of each block of N symbols. The constraint is stronger for CCDDM and SM-1 (for which the energy of each sequence is constant), and becomes weaker for SM- m as m increases (since the energy of each sequence may take m different values). Therefore, as opposed to the ranking defined in terms of linear performance, we expect CCDDM and SM-1 to provide the most effective nonlinearity mitigation, followed by SM-2, SM-3, and so on, while SS should be the least effective. As a result, the optimization of both the DM type and its block length should aim to obtain the best trade-off between two conflicting objectives: the reduction of the rate loss (linear shaping gain) and the reduction of the intensity fluctuations (nonlinear shaping gain). This will be investigated in Section VI.

To study the behavior of different DMs as a function of the block length N , we resort to a trick to emulate SS and SM- m for $N > 512$, when the rate loss of the two methods is very small, but the computation of the required trellis structures becomes nearly unfeasible. In this case, we concatenate the amplitudes generated by $N/512$ independent uses of a DM of block length 512, followed by an interleaver of length N . In this manner, we emulate the correlation induced by a DM of block length N , while achieving almost the same rate loss.

III. NONLINEAR PHASE NOISE METRIC

Different fiber nonlinearity models agree that a relevant portion of nonlinear interference—in particular that generated by the intensity fluctuations of the signal—manifests as phase noise [22], [23], [33], [34]. For instance, the frequency-resolved logarithmic perturbation (FRLP) model describes nonlinear interference as a frequency-dependent phase noise that can be expressed as a quadratic form of the symbols transmitted in a certain time window around the considered

time on the (self- or cross-) interfering channels [34], [37].³ For i.i.d. symbols, the variance of this phase noise depends on the kurtosis of the symbols, so that non-constant-envelope modulations (e.g., QAM or Gaussian modulation) cause a stronger NLI than constant-envelope modulations (e.g., PSK) [34]. However, the nonlinear phase noise generated by non-constant-envelope modulations is strongly correlated in time, so that it can be mitigated by a suitable carrier-phase recovery algorithm, after which its variance practically reduces to that of constant-envelope modulation [38]. Here, we extend the analysis to the case of correlated symbols, such as those generated by the PAS schemes described in Section II, with the aim of finding a suitable metric to predict the dependence of the generated NLI on the PAS block length, accounting for the possible presence of a carrier-phase recovery algorithm. With respect to [34], since removing the i.i.d. assumption significantly complicates the analysis [39], we further simplify the FRLP model to obtain a nonlinear phase noise model that depends only on signal intensity, and resort to a numerical approach for the computation of the variance.

The simplified nonlinear phase noise model is derived from the FRLP model [34] by following the same approach used in [40]–[43] to develop the enhanced split-step Fourier method (ESSFM) and the coupled-channel ESSFM (CESSFM) algorithms for DBP. By considering only the terms on the diagonal of the quadratic form in [34, eq. (18)], neglecting (or averaging out) their dependence on frequency, and accounting for the contributions of the two polarizations of each interfering channel, we eventually obtain a simple phase noise term that depends on the intensity variations of all the interfering channels. Specifically, considering M WDM channels, denoting by $x_i[k]$ and $y_i[k]$ the normalized k th symbols transmitted on the two polarizations of the i th channel, the corresponding output samples after dispersion compensation can be expressed as $x_i[k] \exp(-j\theta_i[k])$ and $y_i[k] \exp(-j\theta_i[k])$, where

$$\theta_i[k] = \sum_{\ell=1}^M \bar{\phi}_{i\ell} \sum_{m=-N_c}^{N_c} C_{\ell-i}[m] (|x_\ell[k+m]|^2 + |y_\ell[k+m]|^2) \quad (1)$$

is the overall nonlinear phase rotation [43]. In (1), $C_{\ell-i}[m]$ ($m = -N_c, \dots, N_c$) are $2N_c + 1$ real coefficients accounting for the interaction of dispersion and nonlinearity induced by channel ℓ over channel i ; $\bar{\phi}_{i\ell} = (3/2 - \delta_{i\ell}/2)\gamma \int_0^L P_\ell(\zeta) d\zeta$ is the average nonlinear phase rotation induced by channel ℓ over channel i , with $P_\ell(\zeta)$ the power of channel ℓ at distance ζ , L the length of the link, γ the nonlinear coefficient of the fiber, and $\delta_{i\ell}$ the Kronecker delta. The coefficients can be evaluated analytically from [34, eq. (19)]⁴ as

$$C_n[m] = T^2 \int_{\frac{2n-1}{2T}}^{\frac{2n+1}{2T}} \int_{\frac{2n-1}{2T}}^{\frac{2n+1}{2T}} K(\mu, \nu) e^{-j2\pi(\mu-\nu)mT} d\mu d\nu \quad (2)$$

where T is the symbol time and $K(\mu, \nu)$ is a function that depends on the link characteristics and accounts for the nonlinear interaction efficiency of different frequency components. Considering a dispersion-unmanaged link made of N_s identical fiber spans of length L_s , with attenuation coefficient α , dispersion parameter β_2 , nonlinear coefficient γ , and ideal dispersion compensation at the end of the link, we have

$$K(\mu, \nu) = \frac{\exp[-\alpha + j4\pi^2\beta_2\nu(\nu - \mu)L_s] - 1}{-\alpha + j4\pi^2\beta_2\nu(\nu - \mu)} \times \frac{\exp[j4\pi^2\beta_2\nu(\nu - \mu)N_sL_s] - 1}{\exp[j4\pi^2\beta_2\nu(\nu - \mu)L_s] - 1} \frac{\alpha}{N_s(1 - e^{-\alpha L_s})} \quad (3)$$

Interestingly, there is a clear similarity between the nonlinear phase rotation in (1) and the weighted sum of symbol energies used in [19], [36] to define the energy dispersion index (EDI) and the exponentially-weighted EDI (EEDI) and predict the nonlinear shaping gain that occurs in a PAS system using CCDM. For example, the EEDI is defined as [36]

$$\text{EEDI} = \frac{\text{Var}(G^\lambda[k])}{E(G^\lambda[k])} \quad (4)$$

where

$$G^\lambda[k] = \sum_{m=-\infty}^{+\infty} \lambda^{|m|} |x_i[k+m]|^2 \quad (5)$$

and $0 \leq \lambda \leq 1$ is a forgetting factor.⁵ This similarity provides a physical explanation of why EDI and EEDI are good predictors of the nonlinear shaping gain (when they are small, the signal is affected by less nonlinear phase noise). The main difference between (5) and (1) is that the coefficients in (1) depend on the link characteristics and can be obtained analytically, while the parameter λ in (5) (or the window length W in the EDI) is optimized a posteriori, through extensive simulations, to maximize the correlation with the system performance. Moreover, (1) accounts for both polarizations and includes the interfering channels.⁶ Therefore, we propose to replace the EDI or EEDI with the variance of (1) as a predictor of the nonlinear shaping gain of PAS systems. This solution avoids the use of extensive simulations, poses performance prediction on a more physical ground—relating it to the amount of nonlinear phase noise accumulated during propagation—and, as shown below, allows to easily account for the impact of CPR.

In order to account for the randomness of the carrier phase and its temporal variations due to laser phase noise, coherent optical receivers usually include a CPR algorithm. Practical algorithms, though not specifically designed for this purpose,

³Though the window formally extend over an infinite time, the coefficients of the quadratic form rapidly decays outside a finite time window determined by the walk-off time between the frequency components involved in the interference process.

⁴In this case, we consider only the diagonal terms of the quadratic form, neglect their dependence on frequency, assume an ideal sinc pulse shape, and adopt a different normalization

⁵A similar definition holds for the EDI, with the only difference of considering a finite sum of W elements with $\lambda = 1$.

⁶The recently proposed lowpass filtered symbol-amplitude sequences (LSAS) metric also allows to account for inter-polarization and inter-channel effects [44].

can partly mitigate also the nonlinear phase noise in (1), reducing its variance. Of course, the amount of nonlinearity that can be mitigated depends on the specific algorithm and on the width of the time window over which the carrier phase is estimated (or any other parameter playing an analogous role). As with the conventional phase noise due to lasers, a longer time window allows to average out more effectively the impact of additive white Gaussian noise on the estimate, but reduces the ability to track fast changes of the phase.

The above considerations have two important consequences. First, when estimating the effectiveness of PAS as a nonlinear mitigation strategy, the presence of CPR should be accounted for. Second, the optimization of the PAS block length N and of the CPR half time window N_{CPR} are intertwined: they depend on each other and should be done jointly, accounting for the link configuration, the signal-to-noise ratio, and the laser linewidth.

With this in mind we define the nonlinear phase noise (NPN) metric (for the generic i th channel) as

$$\sigma_{\theta}^2 = \text{Var}(\theta_i[k] - \hat{\theta}_i[k]) + \sigma_{\xi}^2 \quad (6)$$

where

$$\hat{\theta}_i[k] = \frac{\sum_{m=-N_{\text{CPR}}}^{N_{\text{CPR}}} \theta_i[m+k]}{2N_{\text{CPR}} + 1}. \quad (7)$$

is the noiseless estimate of the nonlinear phase rotation at time k provided by the CPR, which we assume to equal the average nonlinear phase noise measured over a window of $2N_{\text{CPR}} + 1$ symbols around the k th symbol, and σ_{ξ}^2 is the variance of the noise affecting the CPR estimate. In general, the latter depends on the specific CPR algorithm, on its block length (or other equivalent parameter), and on the signal-to-noise ratio (SNR). Here, for the sake of simplicity, we assume

$$\sigma_{\xi}^2 = \frac{(2E_s/N_0)^{-1}/(2N_{\text{CPR}} + 1)}{e_{\text{CPR}}} \quad (8)$$

where the numerator is the Cramér–Rao lower bound, and $e_{\text{CPR}} \leq 1$ is a coefficient that measures the efficiency of the CPR algorithm with respect to the bound [45]. In principle, different definitions of (7) and (8) could be employed to account more precisely for the actual behavior of a specific CPR algorithm, though this is outside the scope of this work.

IV. SIMULATION SETUP

The system setup is sketched in Fig. 3, and is the same considered in [1]. A stream of uniformly distributed bits—representing the information bits after FEC encoding—feeds the PAS block (see Section II), which maps the bits to symbols of a dual polarization 256 quadrature amplitude modulated (QAM) constellation with rate 6 bits/symbol/pol. Using a root raised cosine (RRC) pulse with rolloff 0.1 and baud rate $R_s = 41.67$ GBd, the signals corresponding to 4 adjacent channels are multiplexed in a single superchannel, the superchannel of interest (SCOI), with 75 GHz spacing. Two additional superchannels, with the same properties of the SCOI, are also multiplexed, such that 12 evenly spaced channels are transmitted over an overall bandwidth of 900 GHz. The generated WDM waveform is launched into the link, composed of several

spans of 80 km single mode fiber (SMF) with dispersion $D = 17$ ps/nm/km, Kerr parameter $\gamma = 1.3$ W⁻¹km⁻¹, and attenuation $\alpha_{\text{dB}} = 0.2$ dB/km. After each span, an erbium-doped fiber amplifier (EDFA) with a noise figure of 5 dB compensates for loss. At the end of the link, the side superchannels are filtered out, and the 4 channels of the SCOI are demultiplexed. The transmitter and receiver laser linewidth $\Delta\nu$ are set to either 0 or 100 kHz. Each channel undergoes: (i) either ideal digital back propagation (DBP) or electronic dispersion compensation (EDC), (ii) matched filtering, (iii) sampling at symbol time, and (iv) CPR. Finally, the average achievable information rate (AIR) of the 4 channels of the SCOI is evaluated, representing the average information per symbol that can be reliably transmitted on each polarization and channel of the SCOI, assuming an ideal FEC and bit-wise mismatched decoding optimized for the AWGN channel [10], [46], [47].

As regards CPR, two different approaches are considered: mean phase rotation (MPR) and blind phase search (BPS). On the one hand, MPR is the typical approach employed in simulations—when the laser phase noise is not considered and, thus, CPR not required—to remove the (constant in time) expected value of the nonlinear phase rotation induced by fiber nonlinearity for a given total launch power. In practice, the MPR is estimated by a simple data-aided procedure—i.e., by averaging the instantaneous phase rotation experienced by all the transmitted symbols after propagation—and then removed from all the received symbols. On the other hand, BPS is a practical CPR algorithm typically employed with QAM constellations to track the random fluctuations of the carrier phase induced by laser phase noise [45]. In a nutshell, BPS estimates the carrier phase at discrete time k as the phase rotation (selected among a certain number of test phases) that minimizes the mean square error between the rotated symbols and the corresponding QAM decisions over a window of $2N_{\text{CPR}} + 1$ symbols centered at time k . A shorter window can track faster phase variations, whereas a longer window is required to average out the impact of ASE noise more effectively. The optimal window width is the trade-off between these two effects. In the following, we optimize N_{CPR} numerically and consider 64 test phases in a $\pi/2$ interval. The MPR is nearly equivalent to a BPS with $N_{\text{CPR}} \rightarrow \infty$.

The phase estimated by BPS is affected by an ambiguity of multiples of $\pi/2$ due to the 4-fold rotational symmetry of conventional QAM constellations. This ambiguity may induce detrimental cycle slips, but can be avoided by using, for example, differential coding or pilot symbols [45]. In our simulations, for the sake of simplicity, when laser phase noise is included in the system, we further apply a supervised cycle-slip compensation after BPS [15].

V. NUMERICAL RESULTS

First, we investigate the performance of the different PAS and bit-to-amplitude mapping schemes presented in Section II. Figure 4 compares the performance of the serial and parallel bit-to-amplitude maps at the optimal launch power for different block lengths. In this case, SS is used (implemented with

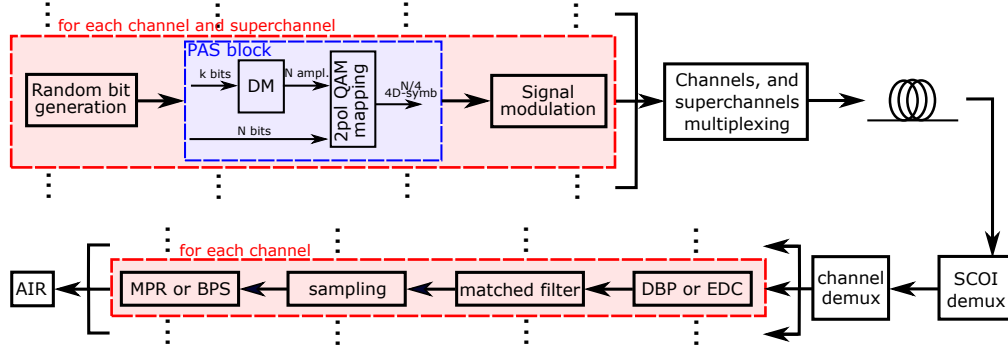

Figure 3. System setup: WDM modulation with PAS block, fiber propagation, and AIR evaluation after channel demultiplexing, EDC or DBP and MPR or BPS.

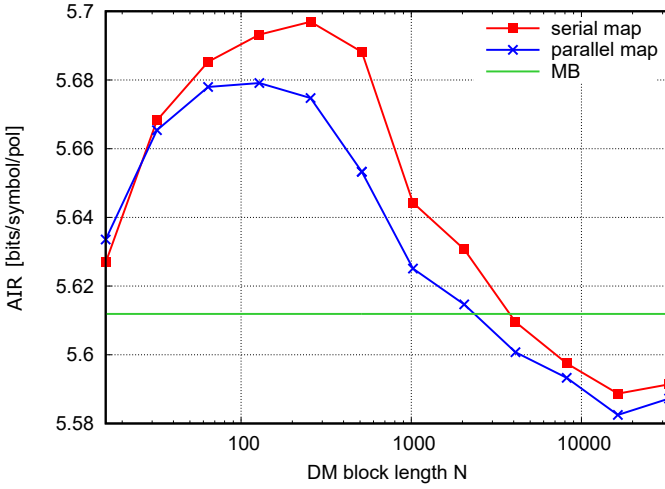

Figure 4. AIR versus block length for different strategies to map amplitudes to symbols. $15 \times 80\text{km}$ link, EDC, $\Delta\nu = 0$ kHz, no BPS, SS.

the ESS algorithm), DBP is not applied, the laser linewidth is set to zero, and the BPS carrier-recovery algorithm is not employed. As a reference, the performance obtained with MB-distributed i.i.d. symbols (optimal in the linear regime) is also shown. When the block length is very short, up to $N \approx 32$, the two maps perform the same, since the performance is limited by the large rate loss. For longer block lengths, the serial map performs better than the parallel one and achieves the highest AIR, with a gain of approximately 0.02 bits/symbol/pol over the parallel map—a similar behaviour was shown in [48], [49] for a single polarization QAM map. The superiority of the serial map is explained by the fact that, for a given DM block length, it constrains the signal energy on a four-time shorter time interval (twice shorter in the single-polarization case) compared to the parallel map, reducing the intensity fluctuations and the corresponding nonlinear phase noise. Both curves improve up to an optimal point ($N \approx 256$ and $N \approx 128$ for the serial map and for the parallel map, respectively) and decrease afterwards to approach the MB curve for $N \rightarrow +\infty$. The peaky behaviour of both curves and the presence of a nonlinear shaping gain compared to the MB reference curve are analyzed in detail in the following, where only the serial map is considered, due to its superior performance.

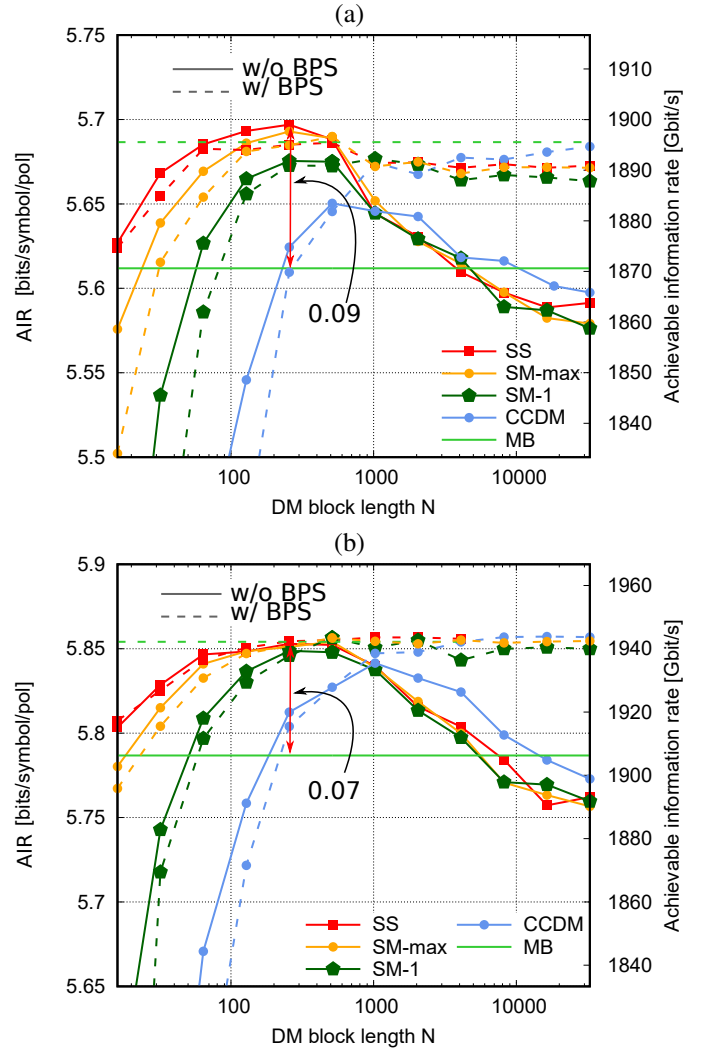

Figure 5. Maximum AIR versus DM block length for $15 \times 80\text{km}$ link with different DM techniques and with and without BPS (a) EDC with $N_{\text{CPR}} = 24$, and (b) DBP with $N_{\text{CPR}} = 16$. $\Delta\nu = 0$ kHz.

The performance of different DMs are compared in Figs. 5(a)–(b) as a function of the DM block length and with (solid lines) or without (dashed lines) BPS, for the case without DBP in (a) and when ideal DBP is included in (b).

On the one hand, Fig. 5(a) shows that, when BPS is not employed, the AIR improves up to a certain optimal value of the block length, after which it decreases again, approaching the AIR obtained with i.i.d. MB symbols (the distribution obtained when the DM block length tends to infinity). The difference between the peak performance and the MB line is the nonlinear shaping gain [4], [16], [18]. This behaviour depends on the combination of two opposing trends: on the one hand, a longer block length implies a lower rate loss and hence a better linear performance; on the other hand, it also implies a weaker correlation between the symbols produced by the DM, whose intensity fluctuates in time more freely, causing a stronger nonlinear phase noise. The optimal block length is the trade-off between linear performance (rate loss) and nonlinear shaping gain (correlations induced by DM). A similar behavior is observed for all the considered DMs, and both with or without DBP. However, the nonlinear shaping gain is the largest for the SS (approximately equal to 0.085 bit/symbol/pol), just slightly smaller for SM, smaller for SM-1, and the smallest for CCDM, following the same ranking shown in the linear regime. Since SM reduces the intensity fluctuations of the signal with respect to SS, one could expect the SM or the SM-1 to provide the best nonlinear performance—as shown in [31] for a 205 km fiber. However, the results show that the linear performance prevails. In fact, a lower rate loss (as for the SS) allows to reduce the DM block length and, consequently, to enforce a stronger constraint on the possible intensity fluctuations of the signal, with less nonlinear phase noise. The nonlinear behavior of the CCDM can be predicted using the energy dispersion index [19], [36]. The superior performance of SS with respect to CCDM in the nonlinear regime was also shown in [50] and experimentally in [51].

On the other hand, Fig. 5(a) shows that when BPS is employed, the performance of all methods improves almost monotonically towards the MB curve, which is higher than without BPS. In this case, the additional nonlinear shaping gain provided by the optimization of the block length is negligible, meaning that the BPS is mitigating the same nonlinear phase noise that would be mitigated by short-block-length PAS. In practice, when the BPS is employed, the optimal performance can be obtained by using PAS with a sufficiently high block length to reduce the rate loss, without a specific block length optimization. In this case, the minimum required block length to achieve the optimal performance depends on the considered DM, but the optimal performance does not. The performance for short block lengths follows the same ranking given in the linear regime, as for the case without BPS. However, for short block lengths, the performance of the curves with BPS are slightly worse than those with BPS—this happens because the BPS (which in this case plays no useful role since the nonlinear phase noise is completely mitigated by the short-block-length PAS and there is no laser phase noise) has been optimized for the MB curve, which has a larger SNR.

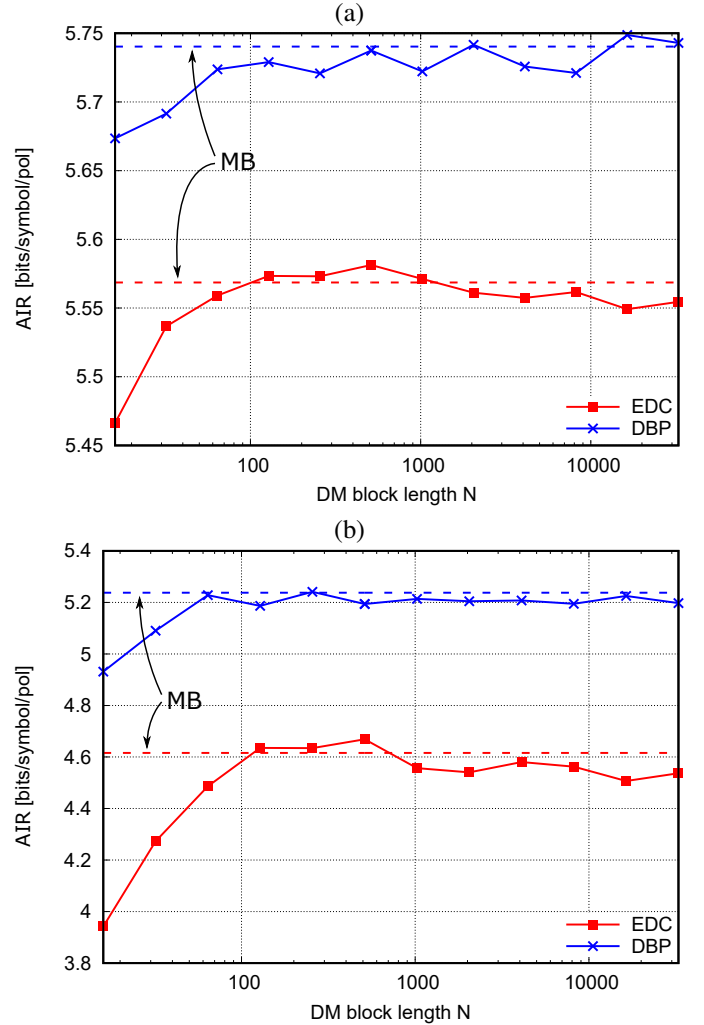

Figure 6. Maximum AIR versus DM block length using SS with $\Delta\nu = 100$ kHz laser linewidth (a) 15 spans with $N_{\text{CPR}} = 38$, (b) 27 spans with $N_{\text{CPR}} = 92$.

Fig. 5(b) shows the same as Fig. 5(a), but adding ideal DBP. The performance improves, since DBP is applied, but the overall behavior does not change with respect to Fig. 5(a)—in fact, even the negligible nonlinear shaping gain observed at intermediate block lengths in Fig. 5(a) vanishes. This result confirms that short-block-length PAS and BPS mitigate the same nonlinear effects (mostly the nonlinear phase noise due to inter-channel nonlinearity), so that the gains they provide, which are similar, do not add up. On the other hand, DBP and PAS (or DBP and BPS) mitigate different nonlinearities— intra- and inter-channel, respectively—and their gains add up.

An important conclusion that can be drawn from Figs. 5(a)–(b) is that the nonlinear shaping gain provided by PAS is not relevant when BPS is employed and optimized to minimize nonlinearities. However, while a CPR algorithm is always included in a system, its time window (in our case, the $2N_{\text{CPR}} + 1$ symbols over which it estimates the phase) is typically dictated by the laser linewidth and the system SNR, so that it cannot be freely optimized to mitigate nonlinear effects. For instance, while nonlinear phase noise is relatively fast and requires a short time window for its mitigation, a

system with relatively good lasers and low SNR may require a much longer time window to achieve its optimal performance. The impact of laser phase noise is investigated in Figs. 6(a)-(b), which show the AIR versus DM block length for a (a) 15×80 km and (b) 27×80 km link, when a laser with linewidth $\Delta\nu = 100$ kHz is considered at the TX and RX sides. The time window of the BPS algorithm—optimized to mitigate the laser phase noise for the MB case when DBP is not applied—is $N_{\text{CPR}} = 38$ in (a) and $N_{\text{CPR}} = 92$ in (b), the difference being due to the lower SNR in the second case. In the 15×80 km link, the BPS algorithm has a sufficiently short time window to mitigate most of the nonlinear phase noise, so that the optimization of the PAS block length does not yield any additional nonlinear shaping gain with respect to the case of infinite block length (i.i.d. samples). On the other hand, in the 27×80 km link, the BPS operates on a longer time window and is not able to mitigate all the nonlinear phase noise—in particular, the portion that is generated by intrachannel nonlinearity, which has faster variations. As a result, in this case a small nonlinear shaping gain of approximately 0.05 bit/symbol/pol can be observed when DBP is not employed (note that Fig. 6(a) and (b) have substantially different vertical scales). A similar behavior—with a larger gain of ≈ 0.1 bit/symbol/pol—was shown in [1], where the laser phase noise was not included.

Next, we consider two rather different links to verify if and how the behaviour highlighted in the previous cases changes when there is much less accumulated dispersion. In both cases, we consider SS-based PAS, EDC at the RX, and we include laser phase noise and the BPS algorithm with optimized N_{CPR} . Fig. 7(a) reports the AIR versus DM block length for a single-span SMF link of length 180 km, with $N_{\text{CPR}} = 60$. In this case, the peak AIR is achieved for an optimal block length $N = 32$ —much shorter than in previous cases, since the lower accumulated dispersion makes high-frequency intensity variations more important in the generation of nonlinear phase noise, reducing the optimal DM block length—with a gain of approximately 0.05 bit/symbol/pol with respect to the ideal case with infinite block length (i.i.d. MB symbols). On the other hand, Fig. 7(b) reports the AIR versus DM block length for a 15×80 km link with full inline dispersion compensation, where each 80 km SMF span is followed by 13 km of dispersion compensating fiber (DCF) with $\alpha_{\text{dB}} = 0.57$ dB/km, $\beta_2 = 127.5$ ps²/km, and $\gamma = 6.5$ W⁻¹km⁻¹. One additional EDFA with a noise figure of 5 dB is added at the input of each span of DCF, setting the launch power in the DCF 4 dB below that in the SMF. In this case, since the SNR is significantly lower than in the previous cases, the BPS must operate on a longer time window to average out the impact of noise, and the best performance is obtained for $N_{\text{CPR}} = 800$ symbols. Differently from the dispersion-unmanaged case, the figure shows that (i) the optimal DM block length is shorter ($N = 64$ rather than $N = 256$), due to the lower accumulated dispersion (as in the single-span case) and (ii) a large nonlinear shaping gain of 0.15 bit/symbol/pol is obtained even if the BPS is employed, since the long BPS performs similarly to MPR and is ineffective against nonlinear phase noise.

To better understand the interaction between nonlinear shap-

ing gain and CPR, Fig. 8 shows the NPN metric (6) as a function of the DM block length and for different values of the BPS half window N_{CPR} , considering the same link as in Fig. 6(a) (dispersion-unmanaged 15×80 km without DBP) and the SS strategy for PAS. The metric is computed for the second channel of the SCOI, $i = 2$, and considering the impact of the 4 channels of the SCOI. For the sake of simplicity, we simply set $e_{\text{CPR}} = 0.008$ in (8), which yields, on average, reasonable results for the considered scenario and range of N_{CPR} values.⁷ At the optimal launch power, the (linear) SNR value is $E_s/N_0 = 17$ dB. For a very long BPS window (e.g., $N_{\text{CPR}} = 512$), the BPS is too slow to track the nonlinear phase noise and behaves in practice as the MPR. In this case, the phase estimate (7) converges to the average nonlinear phase rotation, the variance of the CPR noise (8) vanishes, and the NPN metric (6) measures only the amount of generated nonlinear interference. As a result, the metric behaves similarly to the EEDI: it initially increases with N , until it saturates (for $N \approx 1024$) to the value that would be obtained for i.i.d. MB symbols. In this case, the use of a relatively short block length ($N < 1024$) is beneficial to reduce the nonlinear phase noise. However, the reduction of the block length causes also an increase of the DM rate loss. The combination of these two effects results in the behavior shown in Fig. 5(a) (w/o BPS), with an optimal block length that maximizes the AIR. On the other hand, when decreasing the BPS window, the noiseless phase estimate (7) becomes more accurate, while the variance of the CPR noise (8) increases. In other words, the BPS becomes faster but more noisy. As a result, the NPN metric (6) decreases for long DM block length, where the phase noise term dominates, and increases for short DM block length, where the CPR noise term dominates. Thus, the NPN curves tend to flatten and the dependence on the DM block length becomes weaker. This explains why the behavior of the AIR in Fig. 5(a) changes when the BPS is included: in this case, using a short DM block length is no longer beneficial, since the BPS already mitigates the nonlinear phase noise caused by the intensity fluctuations of the signal. In fact, to go beyond the mitigation capabilities of the BPS and see an additional SNR improvement caused by PAS, the DM block length should be reduced too much (e.g., $N < 256$), where the DM rate loss is however too high. Finally, the use of a too short window (e.g., $N_{\text{CPR}} = 2$ or 8) makes the BPS too noisy, with a significant performance degradation at any DM block length.

Finally, Figs 9(a-c) show the heat maps of SNR, $-NPN$ and $-EEDI$, respectively, as a function of DM block length N (x-axis) and CPR window N_{CPR} (y-axis), in the same setup as Fig. 4, i.e., using SS, dispersion compensation and $\Delta\nu = 0$ kHz laser linewidth, considering the second channel of the SCOI. The SNR is obtained through extensive numerical simulations; the NPN metric is evaluated from (6), with $E_s/N_0 = 17$ dB, $e_{\text{CPR}} = 0.008$, and accounting for the 4

⁷In general, the parameter e_{CPR} depends on the modulation format, SNR, and BPS half window N_{CPR} [45]. Thus, more accurate results could be obtained by a detailed characterization of the BPS behavior and dependence on these parameters. Our simple choice is, however, sufficient to show the accuracy of the proposed metric.

channels of the SCOI; and the EEDI is evaluated from (4),(5) with $\lambda = 0.985$, previously optimized (through numerical simulations) to maximize the correlation with SNR in the case without CPR. Comparing 9(a) and 9(b), it is evident that SNR and -NPN have a similar behavior and are highly correlated: (i) when the block length N is very short, they achieve their best values, which are however not practically useful since associated with a high DM rate loss; (ii) for larger N values, the best performance is obtained when N_{CPR} is large enough to average out the noise and small enough to mitigate nonlinear interference; (iii) with an optimized N_{CPR} , the performance is almost independent of PAS block length N ; (iv) for very large (but suboptimal) N_{CPR} values, BPS behaves as MPR and the dependence of the metric on the DM block length N becomes more evident, causing the nonlinear shaping gain observed in these cases. Conversely, the EEDI shown in Fig. 9(c) is independent of N_{CPR} by definition; therefore, it is weakly correlated with the SNR and has the correct dependence on the DM block length only for very large N_{CPR} (or, equivalently, when MPR is employed). In fact, the correlation coefficient between SNR and $-NPN$ over the entire range of N and N_{CPR} values considered in Fig. 9 is 0.99, while the correlation coefficient between SNR and EEDI is only 0.02. These results confirm that the proposed NPN metric is highly correlated with the system SNR and predict accurately its dependence on the DM block length, even in the presence of CPR.

VI. DISCUSSION AND CONCLUSION

In this work, we have investigated the performance of different PAS schemes in the presence of fiber nonlinearity, considering a conventional WDM setup, different link configurations, and the presence of carrier phase recovery (CPR). First, we have compared different amplitude-to-symbol mapping, showing that it is convenient to pack together the amplitudes produced by a single DM across the four dimensions given by quadratures and polarizations, hence reducing the intensity fluctuations of the signal over time.

Next, we have compared different DM implementations—namely, sphere shaping (SS), shell mapping, and CCDM. In all the considered cases, increasing the DM block length increases the linear shaping gain (since the rate loss decreases) but reduces the nonlinear shaping gain (since the signal intensity can change more freely over time), so that the optimal performance is obtained at some finite block length. Somewhat counterintuitively, SS always yields the best performance in terms of achievable information rate, meaning that its superior linear shaping gain at short block length more than compensates for its lower effectiveness in constraining the intensity fluctuations of the signal. In a typical dispersion-unmanaged WDM scenario, SS with an optimal block length of 256 amplitudes yields a gain of about 0.1 bit/symbol/polarization compared to the ideal case of infinite PAS block length (i.i.d. symbols).

After that, we have shown that the presence of a CPR algorithm (e.g., BPS) may change the overall picture and the above findings quite significantly, reducing the nonlinear shaping gain provided by a short-block-length PAS and making it

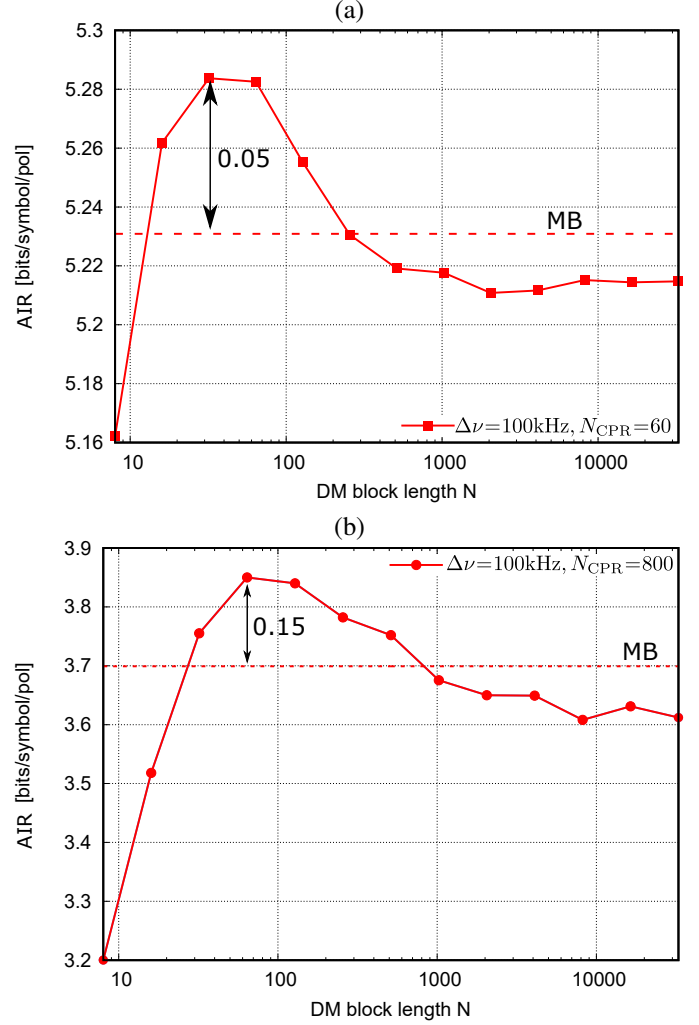

Figure 7. Maximum AIR versus DM block length using SS with $\Delta\nu = 100$ kHz laser linewidth and EDC, for a (a) 180 km single span of SMF, with $N_{\text{CPR}} = 60$, (b) 15×80 km link with full inline dispersion compensation, with $N_{\text{CPR}} = 800$.

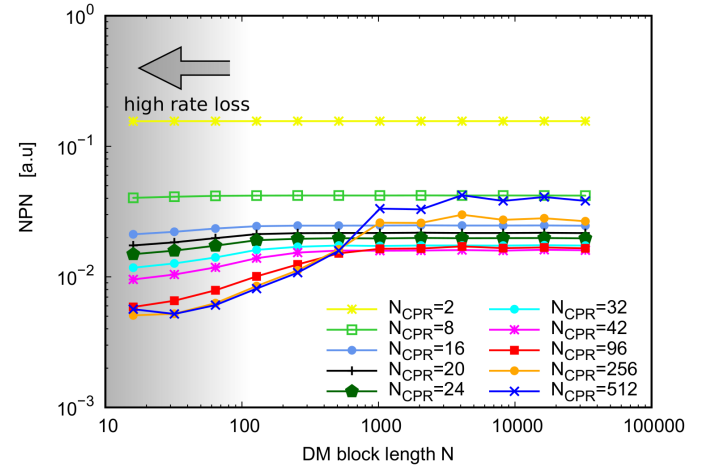

Figure 8. NPN and EEDI as a function of the DM block length, for different CPR window lengths.

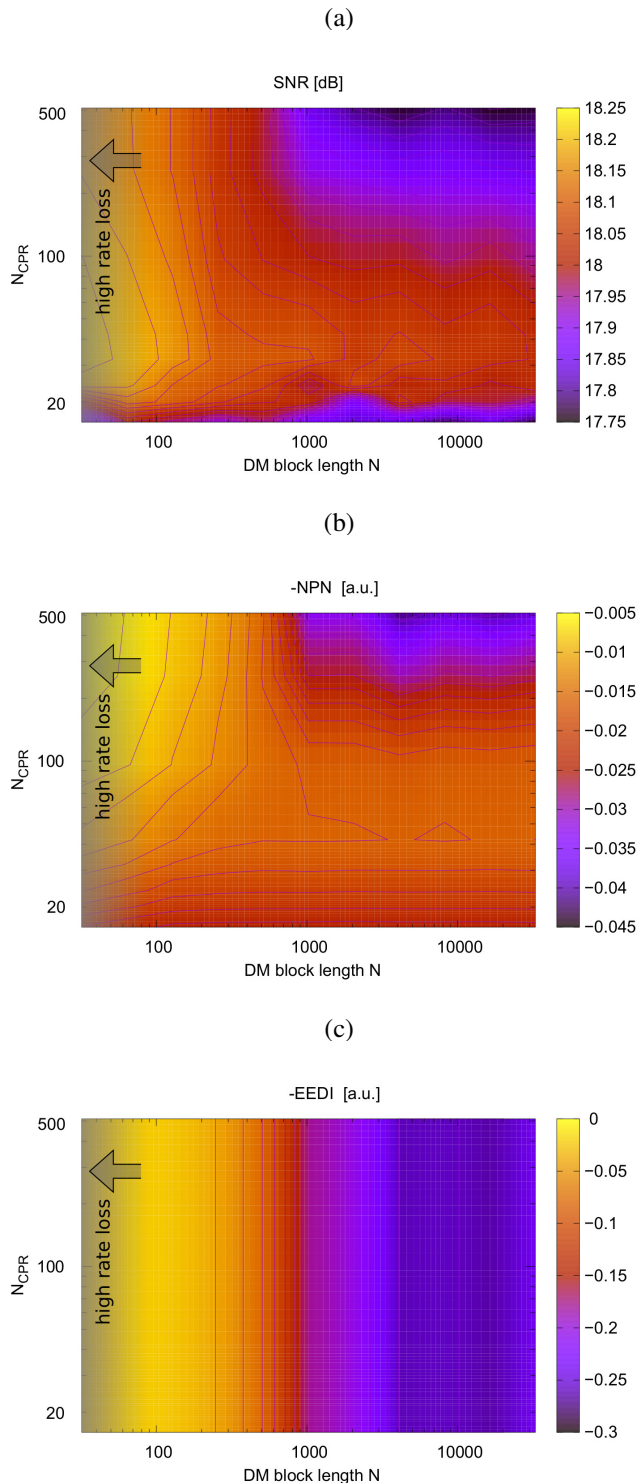

Figure 9. Heat map of (a) simulated SNR (b) $-NPN$ and (c) $-EEDI$ as a function of DM block length N and CPR window N_{CPR} . 15×80 km link, EDC, $\Delta\nu = 0$ kHz.

negligible in most of the scenarios considered in this work. This is due to the ability of BPS (or similar algorithms) to mitigate not only the laser phase noise for which it is mainly employed, but also the nonlinear phase noise caused by fiber nonlinearity. In this case, reducing the PAS block length brings no additional benefits. The latter result appears particularly important when considering that the presence of a CPR algorithm is often neglected in the numerical investigations that can be found in the literature, but is always necessary in real systems. The reduction of the nonlinear shaping gain is more evident in the scenarios where the mitigation of nonlinear phase noise by BPS is more effective, that is, for higher SNR (which allows using a shorter BPS window [45]), more accumulated dispersion (which increases the coherence time of nonlinear phase noise [37]), and/or when DBP is included (which removes intrachannel nonlinearity, against which BPS is less effective). By contrast, a significant nonlinear shaping gain can be still observed in some particular scenarios, such as the link with full inline dispersion compensation and relatively low SNR considered in this work, where SS with an optimal block length of 64 amplitudes yields a gain of about 0.15 bit/symbol/pol with respect to the infinite-block-length PAS, even when an optimized BPS algorithm is included in the system.

Finally, we have introduced a new NPN metric that explains and predict quite accurately all the behaviors described above. The metric is derived from the frequency-resolved logarithmic perturbation [22], [34] and gives an analytical approximation of the variance of the residual (after CPR) nonlinear phase noise generated by the intensity fluctuations of the signal. In contrast to other existing metrics, such as the EDI and EEDI, the proposed NPN metric relies on more physical grounds and contains no adjustable parameters, so that its computation depends directly on the system configuration and does not require any preliminary tuning based on extensive simulations. Moreover, the NPN metric accurately predicts the dependence of system SNR on both the PAS block length and the size of the CPR window.

In conclusion, the results presented in this work highlight the importance of including CPR in the analysis and optimization of PAS in the nonlinear regime. In fact, the dependence of the nonlinear shaping gain on the specific PAS implementation (DM and amplitude-to-symbol mapping) and block length—which is observed in many scenarios in the absence of CPR—may become less relevant in the presence of CPR. In many cases, different DMs may perform equally well in the nonlinear regime, provided that a sufficiently long block length is employed, meaning that other factors (e.g., complexity) may play a more important role in the design of the system. This is, however, not always true, since there exist some specific scenarios (e.g. with low SNR and small accumulated dispersion), where the dependence of nonlinear shaping gain on the employed DM and block length is still relevant. From a practical point of view, the NPN metric proposed in this work allows to account for all these factors accurately, and can be used as a simple guide to jointly optimize PAS and CPR without performing extensive simulations.

REFERENCES

- [1] S. Civelli, E. Forestieri, and M. Secondini, "Interplay of probabilistic shaping and carrier phase recovery for nonlinearity mitigation," in *2020 European Conference on Optical Communications (ECOC)*, IEEE, 2020.
- [2] G. Böcherer, F. Steiner, and P. Schulte, "Bandwidth efficient and rate-matched low-density parity-check coded modulation," *IEEE Transactions on Communications*, vol. 63, no. 12, pp. 4651–4665, 2015.
- [3] F. Buchali, F. Steiner, G. Böcherer, L. Schmalen, P. Schulte, and W. Idler, "Rate adaptation and reach increase by probabilistically shaped 64-qam: An experimental demonstration," *Journal of Lightwave Technology*, vol. 34, no. 7, pp. 1599–1609, 2016.
- [4] T. Fehenberger, A. Alvarado, G. Böcherer, and N. Hanik, "On probabilistic shaping of quadrature amplitude modulation for the nonlinear fiber channel," *Journal of Lightwave Technology*, vol. 34, no. 21, pp. 5063–5073, 2016.
- [5] F. R. Kschischang and S. Pasupathy, "Optimal nonuniform signaling for Gaussian channels," *IEEE Transactions on Information Theory*, vol. 39, no. 3, pp. 913–929, 1993.
- [6] Y. Gültekin, W. van Houtum, and F. Willems, "On constellation shaping for short block lengths," in *2018 Symposium on Information Theory and Signal Processing in the Benelux (SITB 2018)*, pp. 86–96, University of Twente, 2018.
- [7] Y. C. Gültekin, F. M. Willems, W. J. van Houtum, and S. Şerbetli, "Approximate enumerative sphere shaping," in *2018 IEEE International Symposium on Information Theory (ISIT)*, pp. 676–680, IEEE, 2018.
- [8] Y. C. Gültekin, T. Fehenberger, A. Alvarado, and F. M. Willems, "Probabilistic shaping for finite blocklengths: Distribution matching and sphere shaping," *Entropy*, vol. 22, no. 5, p. 581, 2020.
- [9] P. Schulte and G. Böcherer, "Constant composition distribution matching," *IEEE Transactions on Information Theory*, vol. 62, no. 1, pp. 430–434, 2016.
- [10] T. Fehenberger, D. S. Millar, T. Koike-Akino, K. Kojima, and K. Parsons, "Multiset-partition distribution matching," *IEEE Transactions on Communications*, vol. 67, no. 3, pp. 1885–1893, 2018.
- [11] T. Yoshida, M. Karlsson, and E. Agrell, "Hierarchical distribution matching for probabilistically shaped coded modulation," *Journal of Lightwave Technology*, vol. 37, no. 6, pp. 1579–1589, 2019.
- [12] S. Civelli and M. Secondini, "Hierarchical distribution matching: a versatile tool for probabilistic shaping," in *Optical Fiber Communication Conference*, p. Th1G.4, Optical Society of America, 2020.
- [13] S. Civelli and M. Secondini, "Hierarchical distribution matching for probabilistic amplitude shaping," *Entropy*, vol. 22, no. 9, p. 958, 2020.
- [14] P. Nadimi Goki and L. Poti, "Rate loss reduction through look-up table design for hierarchical distribution matcher in probabilistic amplitude shaped systems," in *2021 European Conference on Optical Communication (ECOC)*, IEEE, 2021.
- [15] D. A. Mello, F. A. Barbosa, and J. D. Reis, "Interplay of probabilistic shaping and the blind phase search algorithm," *Journal of Lightwave Technology*, vol. 36, no. 22, pp. 5096–5105, 2018.
- [16] O. Geller, R. Dar, M. Feder, and M. Shtaif, "A shaping algorithm for mitigating inter-channel nonlinear phase-noise in nonlinear fiber systems," *Journal of Lightwave Technology*, vol. 34, no. 16, pp. 3884–3889, 2016.
- [17] A. Amari, S. Goossens, Y. C. Gültekin, O. Vassilieva, I. Kim, T. Ikeuchi, C. M. Okonkwo, F. M. Willems, and A. Alvarado, "Introducing enumerative sphere shaping for optical communication systems with short blocklengths," *Journal of Lightwave Technology*, vol. 37, no. 23, pp. 5926–5936, 2019.
- [18] T. Fehenberger, H. Griesser, and J.-P. Elbers, "Mitigating fiber nonlinearities by short-length probabilistic shaping," in *Optical Fiber Communication Conference*, pp. Th1I–2, Optical Society of America, 2020.
- [19] K. Wu, G. Liga, A. Sheikh, F. M. Willems, and A. Alvarado, "Temporal energy analysis of symbol sequences for fiber nonlinear interference modelling via energy dispersion index," *Journal of Lightwave Technology*, vol. 39, no. 18, pp. 5766–5782, 2021.
- [20] Y. C. Gültekin, A. Alvarado, O. Vassilieva, I. Kim, P. Palacharla, C. M. Okonkwo, and F. M. Willems, "Kurtosis-limited sphere shaping for nonlinear interference noise reduction in optical channels," *Journal of Lightwave Technology*, vol. 40, no. 1, pp. 101–112, 2021.
- [21] J. Cho, X. Chen, G. Raybon, D. Che, E. Burrows, S. Olsson, and R. Tkach, "Shaping lightwaves in time and frequency for optical fiber communication," *Nature communications*, vol. 13, no. 1, pp. 1–11, 2022.
- [22] M. Secondini and E. Forestieri, "Analytical fiber-optic channel model in the presence of cross-phase modulation," *IEEE Photon. Technol. Lett.*, vol. 24, pp. 2016–2019, Nov. 2012.
- [23] R. Dar, M. Feder, A. Mecozzi, and M. Shtaif, "Properties of nonlinear noise in long, dispersion-uncompensated fiber links," *Opt. Exp.*, vol. 21, pp. 25685–25699, Nov. 2013.
- [24] R. Dar and P. J. Winzer, "Nonlinear interference mitigation: methods and potential gain," *J. Lightwave Technol.*, vol. 35, no. 4, pp. 903–930, 2017.
- [25] M. P. Yankov, T. Fehenberger, L. Barletta, and N. Hanik, "Low-complexity tracking of laser and nonlinear phase noise in WDM optical fiber systems," *J. Lightw. Technol.*, vol. 33, pp. 4975–4984, Dec. 2015.
- [26] M. Secondini, E. Agrell, E. Forestieri, D. Marsella, and M. R. Camara, "Nonlinearity mitigation in wdm systems: Models, strategies, and achievable rates," *Journal of Lightwave Technology*, vol. 37, no. 10, pp. 2270–2283, 2019.
- [27] R. Raffie Borujeny and F. Kschischang, "Why constant-composition codes reduce nonlinear interference noise," *arXiv e-prints*, p. arXiv:2203.02641, 2022.
- [28] F. Willems and J. Wuijts, "A pragmatic approach to shaped coded modulation," in *IEEE 1st Symp. on Commun. and Veh. Technol. in the Benelux*, 1993.
- [29] Y. C. Gültekin, W. J. van Houtum, A. G. Koppelaar, and F. M. Willems, "Enumerative sphere shaping for wireless communications with short packets," *IEEE Transactions on Wireless Communications*, vol. 19, no. 2, pp. 1098–1112, 2019.
- [30] Y. Chen, J. Chen, W. Li, M. Zhang, D. Liu, and M. Tang, "Squeezing out the last shaping gain with optimum enumerative sphere shaping for short block lengths," in *2021 European Conference on Optical Communication (ECOC)*, pp. 1–3, IEEE, 2021.
- [31] Y. C. Gültekin, A. Alvarado, O. Vassilieva, I. Kim, P. Palacharla, C. M. Okonkwo, and F. M. Willems, "Mitigating nonlinear interference by limiting energy variations in sphere shaping," in *Optical Fiber Communication Conference*, pp. Th3F–2, Optica Publishing Group, 2022.
- [32] P. Schulte, F. Steiner, and G. Böcherer, "shapecomm WebDM: Online constant composition distribution matcher." <http://dm.shapecomm.de>, July 2017.
- [33] A. Mecozzi and R.-J. Essiambre, "Nonlinear Shannon limit in pseudo-linear coherent systems," *J. Lightw. Technol.*, vol. 30, pp. 2011–2024, June 2012.
- [34] M. Secondini, E. Forestieri, and G. Prati, "Achievable information rate in nonlinear WDM fiber-optic systems with arbitrary modulation formats and dispersion maps," *J. Lightw. Technol.*, vol. 31, pp. 3839–3852, Dec. 2013.
- [35] A. Carena, G. Bosco, V. Curri, Y. Jiang, P. Poggiolini, and F. Forghieri, "EGN model of non-linear fiber propagation," *Opt. Exp.*, vol. 22, pp. 16335–16362, June 2014.
- [36] K. Wu, G. Liga, Y. C. Gültekin, and A. Alvarado, "Exponentially-weighted energy dispersion index for the nonlinear interference analysis of finite-blocklength shaping," in *2021 European Conference on Optical Communication (ECOC)*, IEEE, 2021.
- [37] M. Secondini and E. Forestieri, "Analytical fiber-optic channel model in the presence of cross-phase modulation," *IEEE Photonics Technology Letters*, vol. 24, no. 22, pp. 2016–2019, 2012.
- [38] M. Secondini and E. Forestieri, "On XPM mitigation in WDM fiber-optic systems," *IEEE Photon. Technol. Lett.*, vol. 26, no. 22, pp. 2252–2255, 2014.
- [39] G. Liga, A. Barreiro, H. Rabbani, and A. Alvarado, "Extending fibre nonlinear interference power modelling to account for general dual-polarisation 4D modulation formats," *Entropy*, vol. 22, no. 11, p. 1324, 2020.
- [40] M. Secondini, D. Marsella, and E. Forestieri, "Enhanced split-step Fourier method for digital backpropagation," in *2014 European Conference on Optical Communication (ECOC)*, pp. 1–3, IEEE, 2014.
- [41] M. Secondini, S. Rommel, G. Meloni, F. Fresi, E. Forestieri, and L. Poti, "Single-step digital backpropagation for nonlinearity mitigation," *Photon. Netw. Commun.*, vol. 31, pp. 493–502, June 2016.
- [42] S. Civelli, E. Forestieri, A. Lotsmanov, D. Razdoburdin, and M. Secondini, "Coupled-Channel Enhanced SSFM for Digital Backpropagation in WDM Systems," in *Optical Fiber Communication Conference*, Optical Society of America, 2021.
- [43] S. Civelli, E. Forestieri, A. Lotsmanov, D. Razdoburdin, and M. Secondini, "Multichannel digital backpropagation with XPM-aware essfm," in *17th International Symposium on Wireless Communication Systems (ISWCS)*, 2021.
- [44] M. T. Askari, L. Lampe, and J. Mitra, "2022 nonlinearity tolerant shaping with sequence selection," in *European Conference on Optical Communication (ECOC)*, IEEE, 2022.

- [45] T. Pfau, S. Hoffmann, and R. Noé, “Hardware-efficient coherent digital receiver concept with feedforward carrier recovery for m -qam constellations,” *Journal of Lightwave Technology*, vol. 27, no. 8, pp. 989–999, 2009.
- [46] A. Alvarado, T. Fehenberger, B. Chen, and F. M. Willems, “Achievable information rates for fiber optics: Applications and computations,” *Journal of Lightwave Technology*, vol. 36, no. 2, pp. 424–439, 2018.
- [47] E. Agrell, M. Secondini, A. Alvarado, and T. Yoshida, “Performance prediction recipes for optical links,” *IEEE Photonics Technology Letters*, vol. 33, no. 18, pp. 1034–1037, 2021.
- [48] T. Fehenberger, D. S. Millar, T. Koike-Akino, K. Kojima, K. Parsons, and H. Griesser, “Analysis of nonlinear fiber interactions for finite-length constant-composition sequences,” *Journal of Lightwave Technology*, vol. 38, no. 2, pp. 457–465, 2019.
- [49] W.-R. Peng, A. Li, Q. Guo, Y. Cui, and Y. Bai, “Transmission method of improved fiber nonlinearity tolerance for probabilistic amplitude shaping,” *Optics Express*, vol. 28, no. 20, pp. 29430–29441, 2020.
- [50] A. Amari, S. Goossens, Y. C. Gültekin, O. Vassilieva, I. Kim, T. Ikeuchi, C. Okonkwo, F. M. Willems, and A. Alvarado, “Enumerative sphere shaping for rate adaptation and reach increase in WDM transmission systems,” in *45th European Conference on Optical Communication (ECOC)*, IET, 2019.
- [51] T.-H. Nguyen, S. Mumtaz, A. Lorences-Riesgo, K. Le Trung, D. Le Gac, M. S. Neves, Y. Zhao, Y. Frignac, G. Charlet, and S. Dris, “On the performance of super-symbol PCS-QAM digital subcarrier multiplexing in coherent optical fiber systems,” in *Optical Fiber Communication conference*, Optical Society of America, 2022.