

3.4 Gbit/s visible optical wireless transmission based on RGB LED

G. Cossu,* A. M. Khalid, P. Choudhury, R. Corsini, and E. Ciaramella

Scuola Superiore Sant'Anna, Istituto TeCIP, Via G. Moruzzi 1, Pisa 56124, Italy
g.cossu@sssup.it

Abstract: In this paper, we experimentally realized a gigabit-class indoor visible light communication system using commercially available RGB White LED and exploiting an optimized DMT modulation. We achieved data rate of 1.5 Gbit/s with single channel and 3.4 Gbit/s by implementing WDM transmission at standard illumination levels. In both experiments, the resulting bit error ratios were below the FEC limit. To the best of our knowledge, these values are the highest ever achieved in VLC systems.

©2012 Optical Society of America

OCIS codes: (060.0060) Fiber optics and optical communications; (060.2605) Free-space optical communication.

References and links

1. N. Kumar and N. R. Lourenco, "Led-based visible light communication system: a brief survey and investigation," *J. Eng. Appl. Sci.* **5**, 297–307 (2010).
2. A. M. Khalid, G. Cossu, R. Corsini, P. Choudhury, and E. Ciaramella, "1-Gb/s transmission over a phosphorescent white LED by using rate-adaptive discrete multitone modulation," *IEEE Photon. J.* **4**(5), 1465–1473 (2012).
3. G. Cossu, A. M. Khalid, P. Choudhury, R. Corsini, and E. Ciaramella, "2.1 Gbit/s visible optical wireless transmission," *Proceedings of ECOC 2012*, P4.16(73), Amsterdam, Netherlands, 16–20 Sept. 2012.
4. D. C. O'Brien, L. Zeng, H. Le-Minh, G. Faulkner, J. W. Walewski, and S. Randel, "Visible light communications: challenges and possibilities," *PIMRC*, 1–5, (2008).
5. Y. Zheng and M. Zhang, "Visible light communications – recent progresses and future outlooks," *SOPO*, 1–6 (2010).
6. C. Kottke, J. Hilt, K. Habel, J. Vučić, and K. D. Langer, "1.25 Gbit/s visible light WDM link based on DMT modulation of a single RGB LED luminary," *Proceedings of ECOC 2012*, We.3.B.4(66), Amsterdam, Netherlands, 16–20 Sept. 2012.
7. European standard EN 12464–1: Lighting of indoor work places, (2003).
8. R. A. Shafik, S. Rahman, and R. Islam, "On the extended relationships among EVM, BER and SNR as performance metrics," *ICECE*, 408–411 (2006).
9. D. Hughes-Hartogs, "Ensemble modem structure for imperfect transmission media," U.S. Patent No. 4,833,796, (May 1989).
10. ITU-T Recommendation, G.709/Y.1331.

1. Introduction

In the future, indoor wireless systems will be required to provide gigabit-class connectivity. Currently, optical wireless (OW) is considered as an alternative technology for broadband wireless applications. Among optical wireless solutions, Visible Light Communication (VLC) based on white Light Emitting Diodes (LEDs) is promising for realizing ubiquitous wireless networks, since LEDs would be used for both illumination [1] and wireless transmission simultaneously.

There are two common approaches to produce white light illumination by using LEDs. One involves blue colored LEDs with wide-band phosphors that produce the form white light. The alternative option is by means of red, green and blue (RGB) LEDs. VLC systems were demonstrated with both options [2,3]. The RGB solution is more preferable than phosphorous-based white LED to improve the data rate, since in the latter case, the slow response of the phosphors limit the modulation bandwidth whereas the power efficiency is reduced if combined with blue filter in order to reject the phosphorescent components [4]. Moreover the RGB LEDs offer the possibility for wavelength division multiplexing (WDM)

which further increases overall transmission capacity. However, in order to implement high speed wireless connectivity, the limited modulation bandwidth of the commercial LEDs (10-20 MHz) requires spectrally efficient modulation techniques, e.g. Orthogonal Frequency Division Multiplexing (OFDM) or Discrete Multi-Tone (DMT) [5]. Most recently, we demonstrated highest capacity of 2.1 Gbit/s by using WDM transmission and DMT modulation of commercial RGB LED [3]. Another gigabit experiment was reported by employing similar approach achieving data rate of 1.25 Gbit/s [6].

In this paper we present a significant increase in data rate for both single channel and WDM VLC links. The improvements in capacity have been achieved mainly by optimizing the DMT implementation and using a receiver with appropriate bandwidth. In a first experiment, we used the RGB LED as a single channel source and we achieved 1.5 Gbit/s capacity. In a second experiment we used the RGB LED as a WDM source, i.e. each color carried a different signal, achieving 3.4 Gbit/s aggregate capacity. The resulting bit error ratios (BERs) in both cases were below $2 \cdot 10^{-3}$, i.e., within the Forward Error Correction (FEC) limit. The luminance level at the receiver was always lower than the value indicated by the European Standard for illumination of working environments, which recommends 500 lux [7].

2. Experimental setup

The experimental setups for the two experiments are reported in Fig. 1.

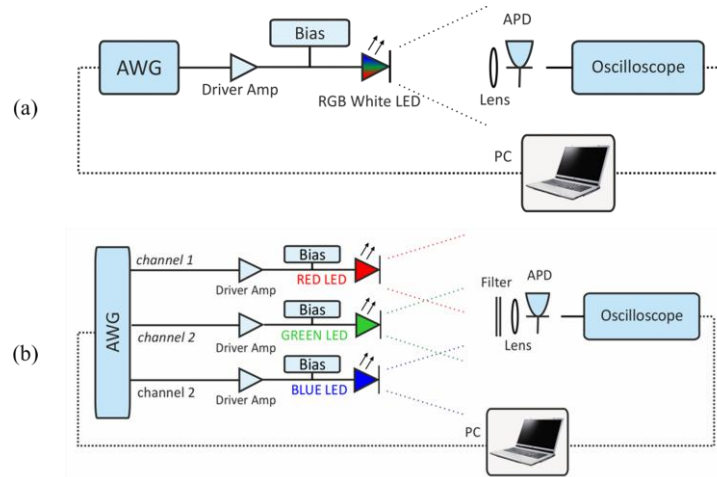

Fig. 1. Experimental setup for single channel (a) and WDM (b) transmission. AWG: Arbitrary Waveform Generator; APD: Avalanche PhotoDiode

The RGB LED (Tx) was a low cost commercially available component (Cree PLCC6 Multichip LED) generating a luminous flux of 6 lm at driving currents of 50 mA (with 120° full emission at half maximum intensity). Its three LED chips had the peak wavelengths of 620 nm (red), 520 nm (green) and 470 nm (blue). In the single channel experiment, the three LED chips were connected in series and modulated together by a single DMT signal consisting of $N = 512$ subcarriers within a bandwidth B of 280 MHz ($B/N = 0.546$ MHz carrier spacing). The bandwidth was chosen to fully exploit the available bandwidth and slow frequency roll off of the LED in order to increase the throughput.

In DMT modulation the single carrier signal is decomposed into a multiple subcarriers. Therefore, the finer the decomposition of the single carrier into N subcarriers, the better the DMT system can adapt to the frequency-dependent response of the channel. After an experimental analysis, presented in this work, we found that a number of 512 subcarriers was a good compromise between capacity and complexity.

We preliminarily estimated the signal-to-noise ratio (SNR) on each subcarrier applying BPSK modulation and evaluating the SNR from the Error Vector Magnitude (EVM) of the received constellations [8]. Bit and power loading [9] algorithm was then applied on N -1 subcarriers to adapt the individual carrier loading to the channel response. Thus we maximized the total data rate having a homogeneous error rate on the subcarriers. The software automatically leaves un-modulated the subcarriers with $\text{SNR} < 6.2$ dB, which is the theoretical limit value for BPSK modulation (minimum bit loading) in order to have a $\text{BER} = 2 \cdot 10^{-3}$.

The DMT signal also included a training sequence for synchronization and further data equalization. In our experiment, the training sequence was made of 20 DMT symbols, which was enough to average out the Gaussian noise. A cyclic prefix was added to reduce the inter-symbol interference. An oversampling factor of 16 was used to smooth the signal and overcome the arbitrary waveform generator (AWG, Agilent M8190a) step-like transitions. The total transmission length of the sequence was 1250 DMT symbols.

The output of the AWG was amplified by means of a power amplifier (Minicircuits, 25 dB gain, 29 dBm minimum output power at 1-dB compression, 130 MHz 3-dB bandwidth), superimposed on a dc bias current (75 mA) and used to drive the LED. At the receiver side (Rx), a lens (Thorlabs, 25 mm diameter) was used to collect the light onto an ac-coupled analogue avalanche photodiode (Hamamatsu APD, 0.42 A/W responsivity at 620 nm and gain = 1) module having 3.14 mm² active area and an integrated transimpedance amplifier (280 MHz 3 dB bandwidth). The received signal was recorded by a real-time oscilloscope (LeCroy HRO66Zi, 2 GSa/s sampling rate). The signal processing (SNR evaluation, DMT sequence generation, BER analysis), was performed off-line by a home-made software.

In the WDM experiment, the three LEDs were separately biased and modulated individually. The DMT signal consisted of $N = 512$ subcarriers within a bandwidth of 250 MHz (0.488 MHz carrier spacing). Two different DMT signals were generated and loaded into AWG. The first one was used to drive the LED under analysis, while the second and its inverted copy drove the others LEDs. In order to test each color separately a band-pass optical filter which select one of them was added at the Rx (peak transmission wavelengths: 629 nm, 530 nm, 452 nm; 3-dB bandwidth of 56 nm, 43 nm, 45 nm respectively).

3. Results and discussions

The main objective of a VLC system is to provide high-speed connectivity without affecting the general illumination of the indoor environment. In our experiment we considered as primary parameter the brightness level at the Rx. The measurements were thus performed varying the illuminance level, measured by a lux-meter, simply adjusting the distance between Tx and Rx. The brightness value indicated in the standards [7] for illumination of working environment is typically 500 lx. In our experiments we used an illuminance below this value, and since we used only one LED, we had distances below 30 cm. In a practical scenario, when deploying several LEDs to meet this requirement, a distance of some meters can be easily achieved.

In Fig. 2(a) we report the single channel transmission capacity as a function of the illuminance at the receiver. A maximum gross capacity of 1.5 Gbit/s was achieved at 410 lux (10 cm) with a $\text{BER} = 1.2 \cdot 10^{-3}$ lower than the FEC limit ($2 \cdot 10^{-3}$) and 1 Gbit/s was achieved at only 25 lx (30 cm). In Fig. 2(b), the channel frequency response in term of SNR at 410 lx is reported. The distributions of bit and power loading for different subcarriers at 410 lx are reported in Fig. 2(c) and Fig. 2(d) respectively. It is expected that these distributions corresponding to the channel response. The bit per symbol, in general, is reduced when decreasing the SNR value. In any group of subcarriers with the same modulation order, the allocated power follows the inverse of the SNR curve, thus increases with the frequency. The receiver used in this experiment has a limit of 32 dB SNR at low frequency. For better exploiting the available electrical power we applied a linear pre-emphasis of 15 dB to the transmitted signal (see Fig. 2(d)).

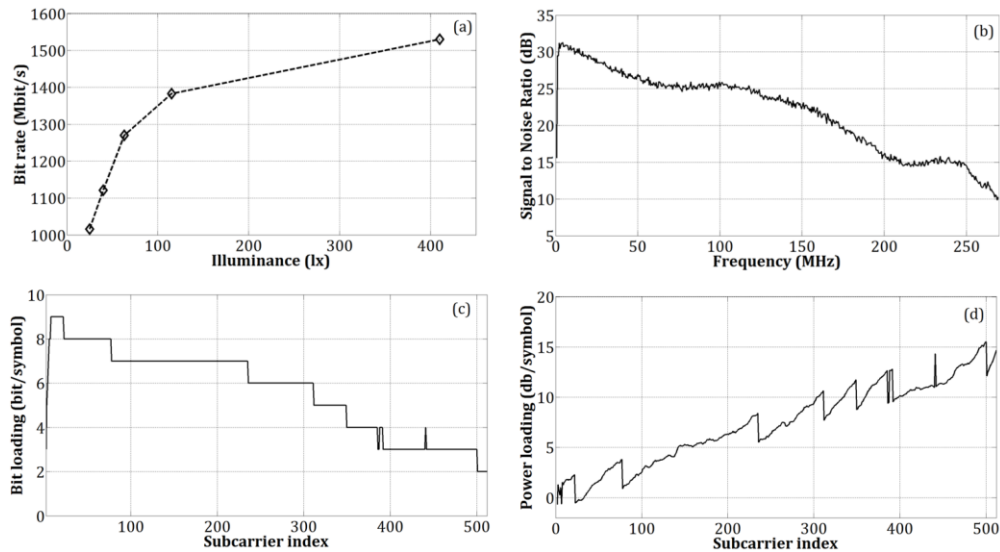

Fig. 2. Experimental results for single channel transmission. (a) Total capacity vs. illuminance at the receiver. (b) SNR vs. frequency at 410 lx. (c) Optimal bit loading distribution at 410 lx. (d) Optimal power loading distribution at 410 lx.

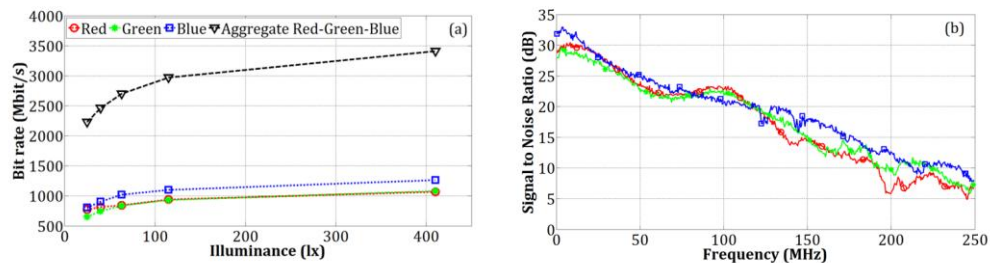

Fig. 3. Experimental results for WDM system. (a) Total aggregate capacity (∇) and single WDM channel capacity (o, *, \square for red, green and blue channels respectively) vs. illuminance at the receiver. (b) Single WDM channel SNR vs. frequency at 410 lx.

In Fig. 3(a) we report the transmission capacity of the WDM system as a function of the total illuminance of the RGB LED. The black triangles represent the aggregate data rate. The red circles, green stars and blue squares show the capacity of the individual WDM channels. A total gross capacity of 3.4 Gbit/s was achieved at 410 lx (10 cm) with $\text{BER} < 2 \cdot 10^{-3}$. The saturation trend observed in Fig. 3(a) (as in Fig. 2(a)) is mostly due to a focusing problem: at distances below 15 cm, the lens forms an image of the source larger than the APD active area, thus the coupling efficiency is reduced. We also note that 2.2 Gbit/s is achieved at only 25 lx (30 cm). This means that, in real scenarios where multiple LEDs will be installed, only a fraction of them can be used also for data modulation purpose, reducing the complexity of the architecture. We also outline that, in a wireless VLC activated home environments the home-users can reduced LEDs intensity (low luminance) at night time while maintaining the high speed connectivity. Moreover, the lens-based direct line-of-sight VLC system, as in this case, have high resilience to background light, due to the small acceptance angle of the Rx.

The capacity of the single WDM channel here is quite lower ($\approx 33\%$) than in the single channel case (Fig. 2(a)), because of the lower received power (the signal was carried by a single color, but the capacity was measured as a function of the total illuminance). Moreover,

we also considered the non-ideal selection of the channels (the bandwidths of the filters are not perfectly matched to the optical spectra of the LEDs) and measured the difference in performance by switching on and off the others two channels while measuring the performance of the channel under investigation. The degradation in terms of bit-rate can be negligible ($<1\%$) for all the conditions. Therefore no penalty significant is due to optical WDM cross-talk. In Fig. 3(b) we report the SNR curves for the WDM channels at 410 lx: these curves show some differences. As an example, blue LED shows a higher SNR respect to the other colors, except around 100 MHz. This explains the better capacity of the blue LED. The improvements from our previous paper [3], are mainly due to an appropriate choice of the APD receiver with a higher bandwidth and the optimization of the DMT code, which is now exploiting the linear pre-emphasis.

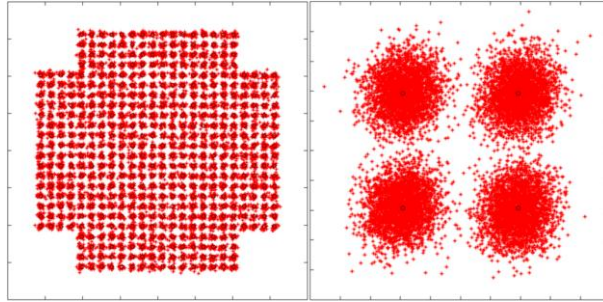

Fig. 4. Received constellation diagrams for the single channel experiment, for 16th subcarrier (left) and for the 512th subcarrier (right).

In Fig. 4 the received DMT signal constellations, for the single channel experiment, are shown for 16th (512-QAM) and 512th (4-QAM) subcarrier, respectively. The constellation can be clearly recognized.

In a real scenario, the typical distances between Tx and Rx should be 2-3 m, thus the focusing problem described above would not be present, and the saturation trend observed in Fig. 2(a) and 3(a) will not limit the total capacity. The gross data rate includes the overhead for training sequence (1.6%) and redundancy of cyclic prefix (1.4%). The FEC overhead (7%) [10] should also be considered in the total overhead.

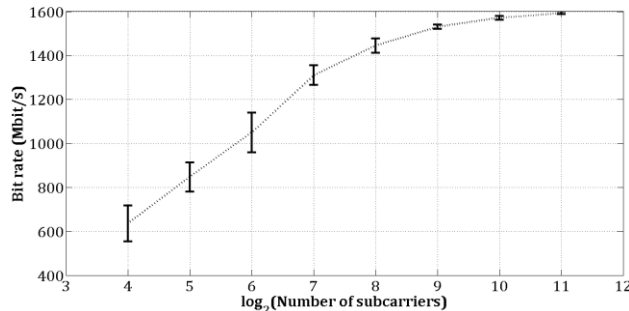

Fig. 5. Experimental capacity for the frequency dependent VLC link for different number of subcarrier.

In Fig. 5, we show the experimental capacity achievable as a function of the number of subcarriers for the single channel experiment. Decreasing the number of subcarrier decrease the overall capacity of the system. This is due to the erroneous estimation of the amplitude and phase response performed by the zero-forcing equalizer in case of high frequency-selective channel. The error bar in the graph represents the standard deviation of the bit-rate evaluation calculated on five subsequent acquisitions. The erroneous estimation of amplitude and phase response leads to a variability in the bit-rate evaluation and this effect is more significant for a low number of carriers.

In terms of achievable real capacity, the data rate increases significantly from 600 Mbit/s using 16 subcarriers up to 1.6 Gbit/s with 2048 subcarriers, while maintaining a constant bit-error-ratio of $1.5 \cdot 10^{-3}$, below the FEC limit. For $N > 2048$ the performance saturated and data rate did not increase significantly. On the other hand, increasing the number of subcarrier, the digital signal processing complexity increases. Therefore 512 subcarriers is very good compromise between the data rate and complexity, losing only 4% of capacity achievable in case of 2048 carriers.

4. Conclusions

A gigabit-class visible OW transmission has been reported based on a commercial RGB LED. We demonstrated 1.5 Gbit/s transmission capacity in the single channel operation and 3.4 Gbit/s transmission capacity in WDM operation. To achieve these results we adopted a DMT modulation based on an optimum bit-power loading allocation. The measured BER values were always below $2 \cdot 10^{-3}$, i.e. within the FEC limit, for both systems. These results were achieved at brightness level of 410 lx. Further improvements may be expected by a suitable choice of the amplifier bandwidth (280 MHz instead of 130 MHz) and overcoming the focusing problem increasing the distance between transmitter and receiver using several LEDs.